

# Efficient Signal and Power Integrity Analysis Using Parallel Techniques

Tao Su, Xiaofeng Wang, Zhengang Bai, Venkata Vennam

Sigrity, Inc.

Santa Clara, USA

Shanghai, China

Contact: [tsu@sigrity.com](mailto:tsu@sigrity.com)

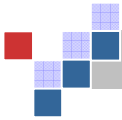

# Contents

- Introduction
- Hyperthreading, Multithreading, Multicore and Distributed computing
- Application examples
- Closing remarks

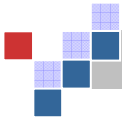

# Introduction

- **Foundation analysis technology**
  - Signal integrity / power integrity
  - Advanced capability and flexibility
- **Increasing product breadth**
  - Multi-domain capability
  - IC package layout
- **Targeted solutions**
  - Specific applications
  - Useful for non-experts

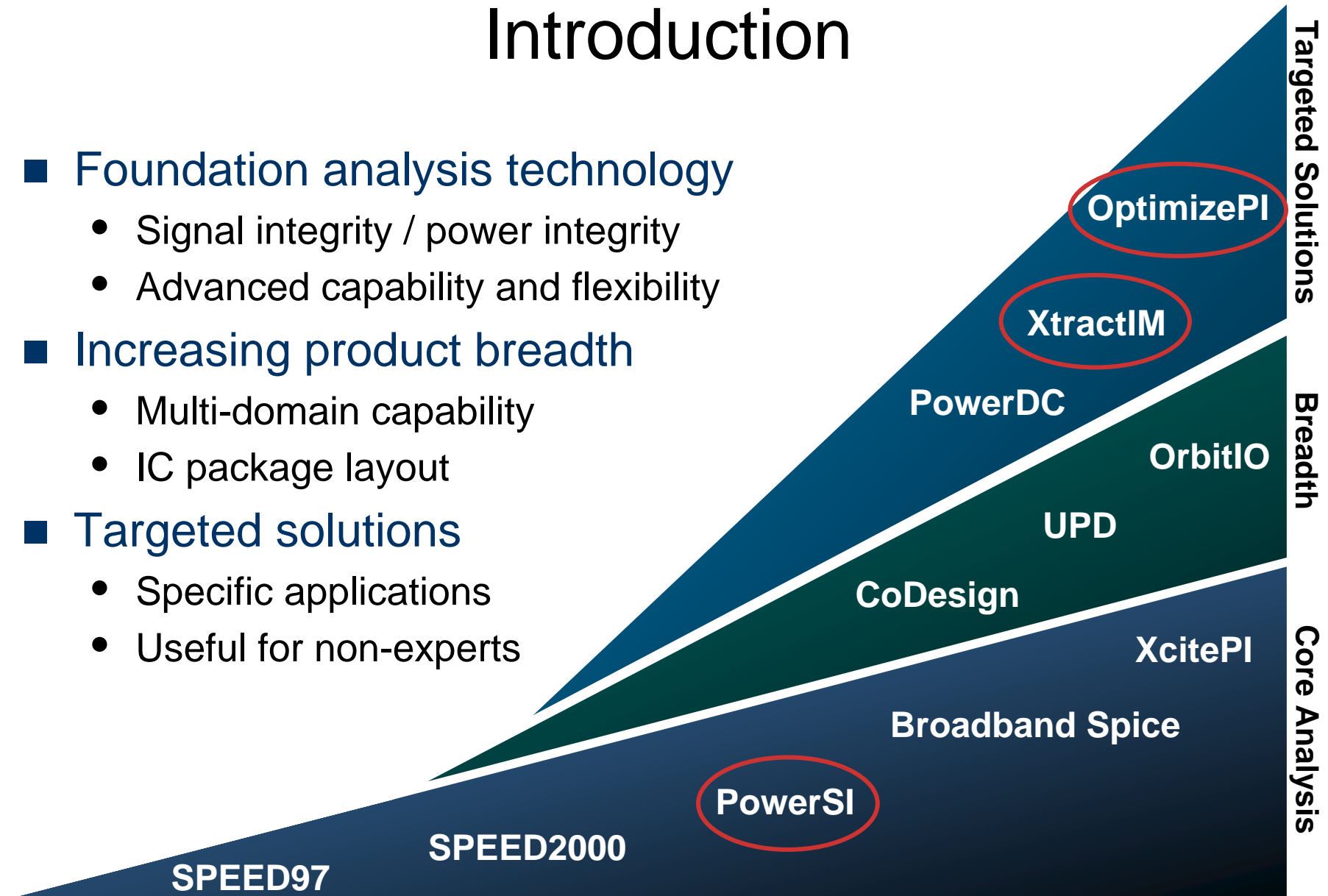

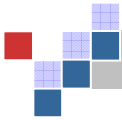

# Multitasking vs. Multithreading

- Multitasking operating systems run multiple programs simultaneously.
- OS is responsible for splitting the time among the different programs that are running.
- Multithreading enables users and programs to accomplish multiple simultaneous tasks.

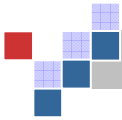

# Evolution of Multi-Core Technology

## Single-threading:

Only one task processes at one time.

**Multitasking and Multithreading:** Two or more tasks execute at one time by using content switching.

**Hyper-threading Technology:** Two single threads execute simultaneously on the same processor core.

**Multi-core Technology:** Computational work of an application is divided and spread over multiple execution cores.

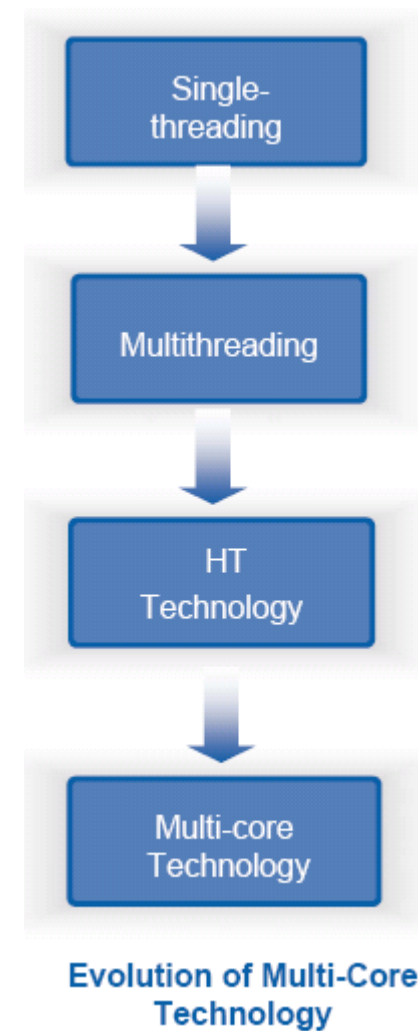

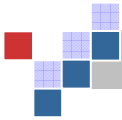

# Hyper-Threading vs. Multi-Core

## HT Technology:

- One execution core in a processor is shared by two threads.
- The execution core executes one thread by utilizing those resources that the other thread is not using.
- Resource conflicts can occur when two threads are assigned the same task.

## Multi-Core Technology:

- Two or more independent execution cores are embedded in a single processor.
- Each thread is executed by an independent execution core.
- Each thread runs in parallel manner effectively.

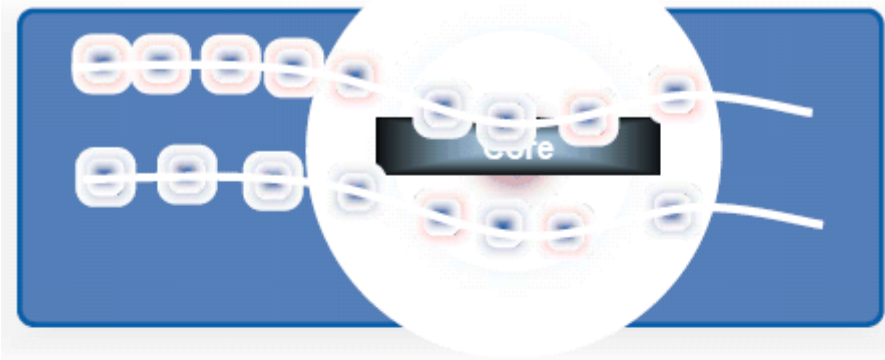

Processor with HT Technology

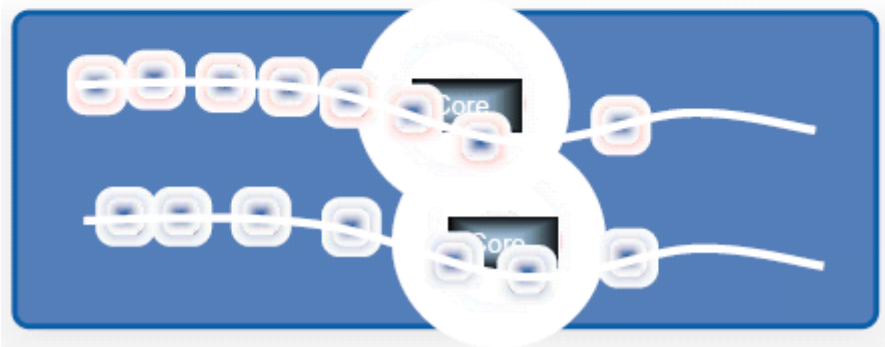

Processor with Multi-Core Technology

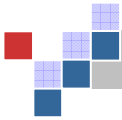

# Multi-Threaded Execution

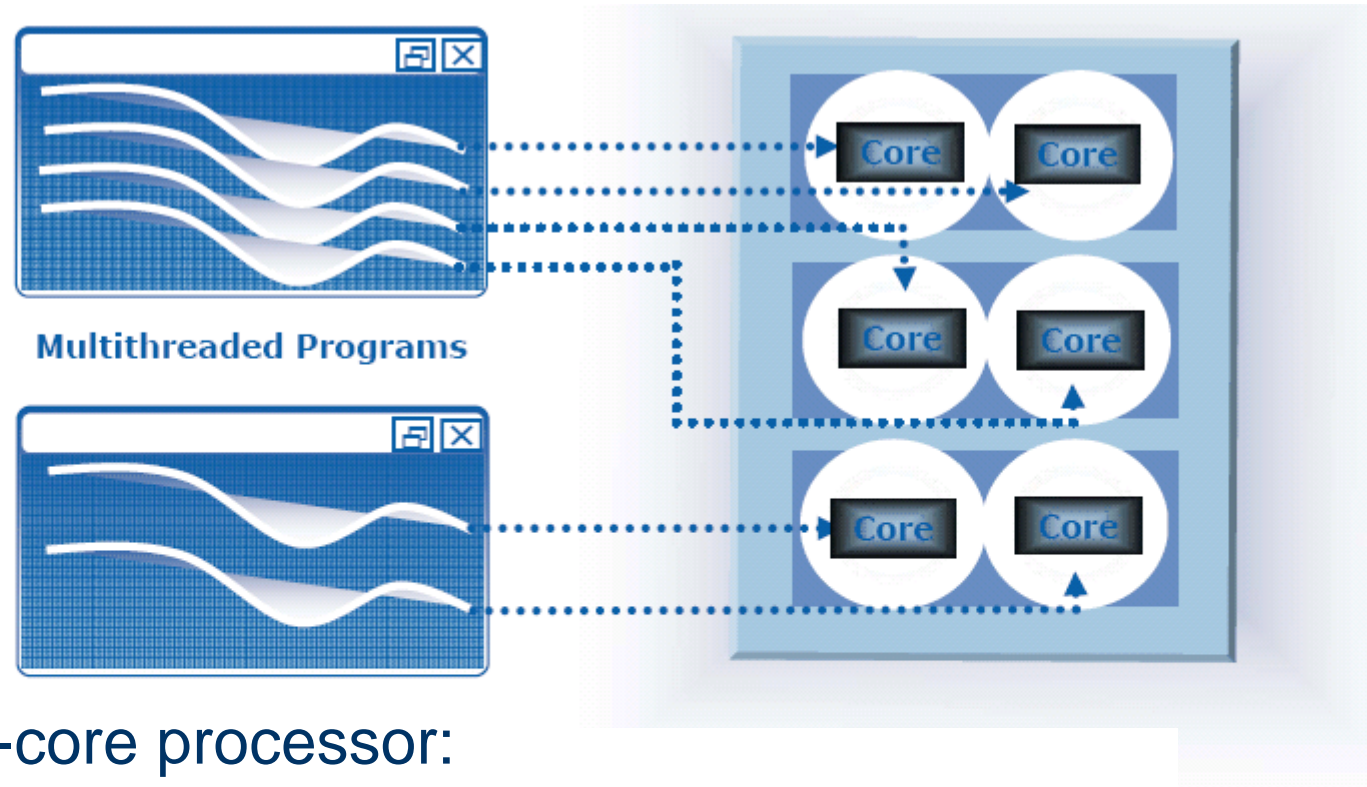

In a multi-core processor:

- Each thread is executed concurrently in each execution core.
- Each thread has its own hardware execution environment.
- Multiple tasks can be executed concurrently.

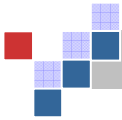

# Threading Methodology

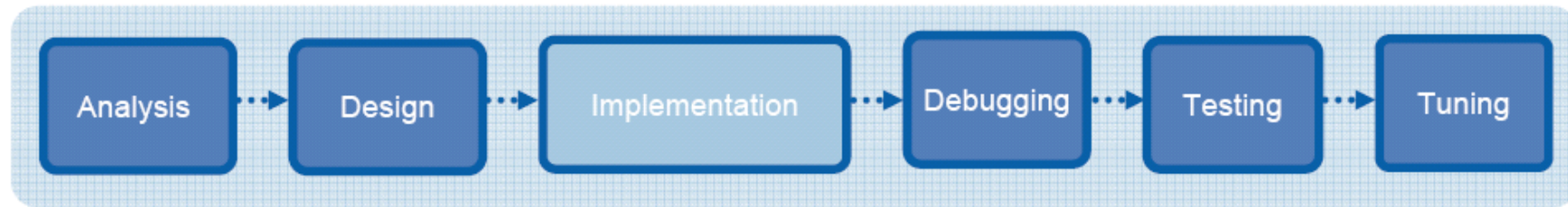

- Multithreaded applications are difficult to understand, debug and optimize.
- Selecting the right threading approach is crucial.
- When threading strategies are well planned, application design and development effort is streamlined.

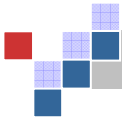

# Typical Electrical Package/PCB Analysis Flow (SPEED tool set)

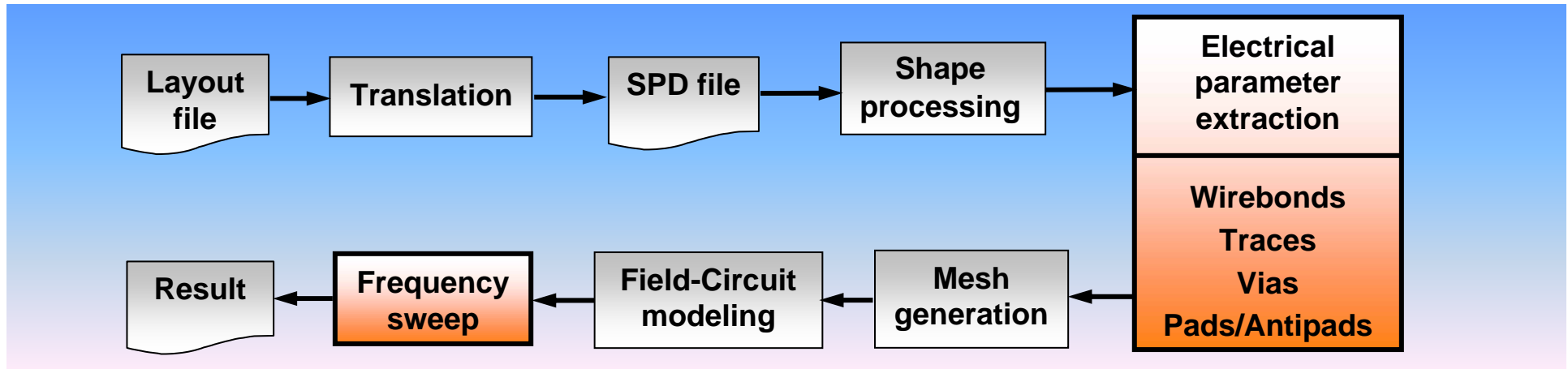

- PowerSI** – General purpose full-wave tool for IC packages and PCBs
- XtractIM** – Customized full IC package extraction
- OptimizePI** – Package/PCB Decap Optimization

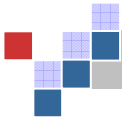

# Sigrity's Solver Technology

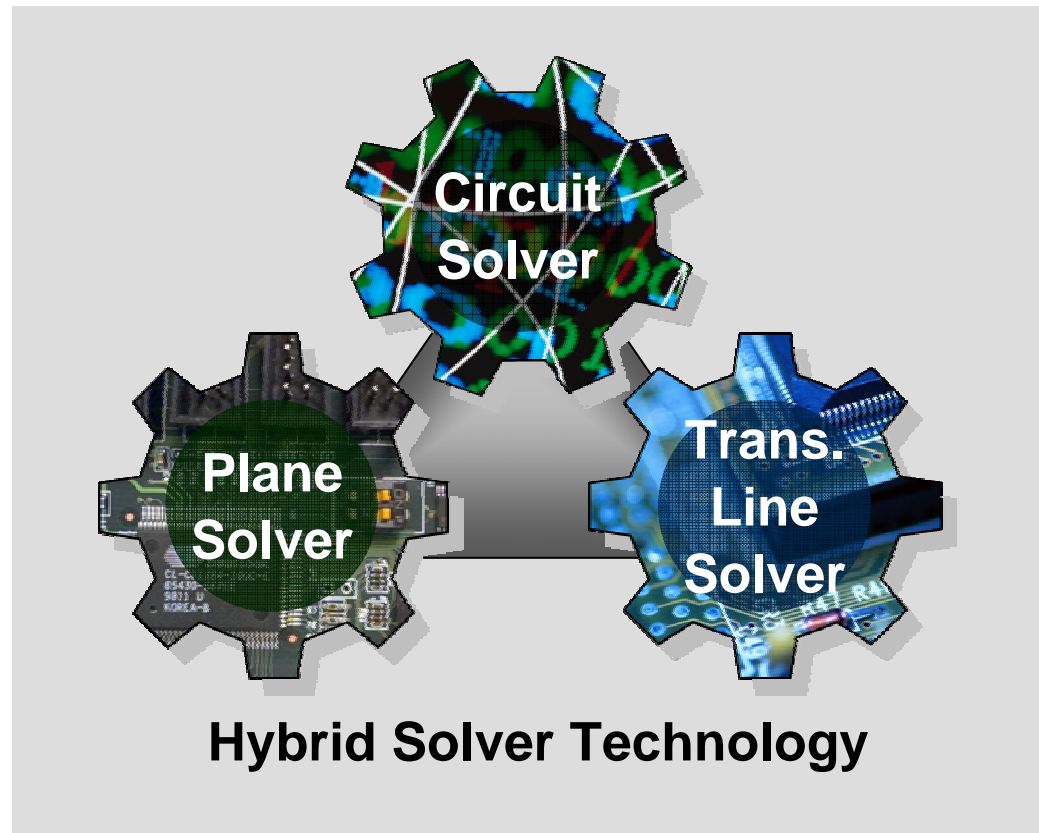

Frequency-domain simulation needs assembling individual systems together.

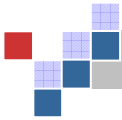

# Achieving Optimum Performance

- Decide when to use multithreading
- Logical –vs- Physical processors
- Load balancing
- Thread safety
- Waiting for shared resources
- Granularity
- Memory leaks

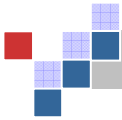

# Controlling the Number of Processors

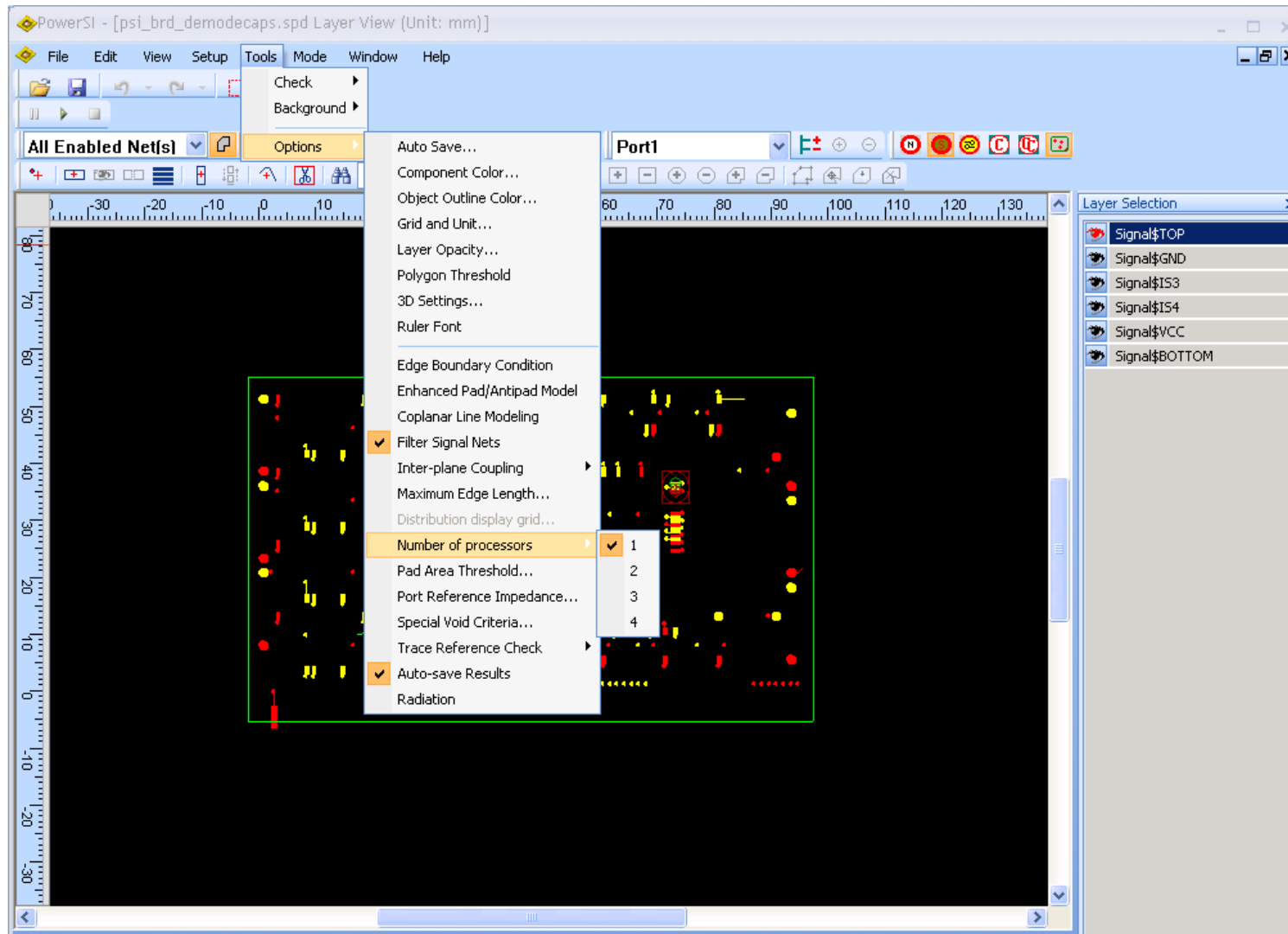

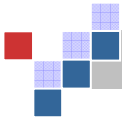

# Speed-up with Multiple Threads

## Electrical modeling of pads

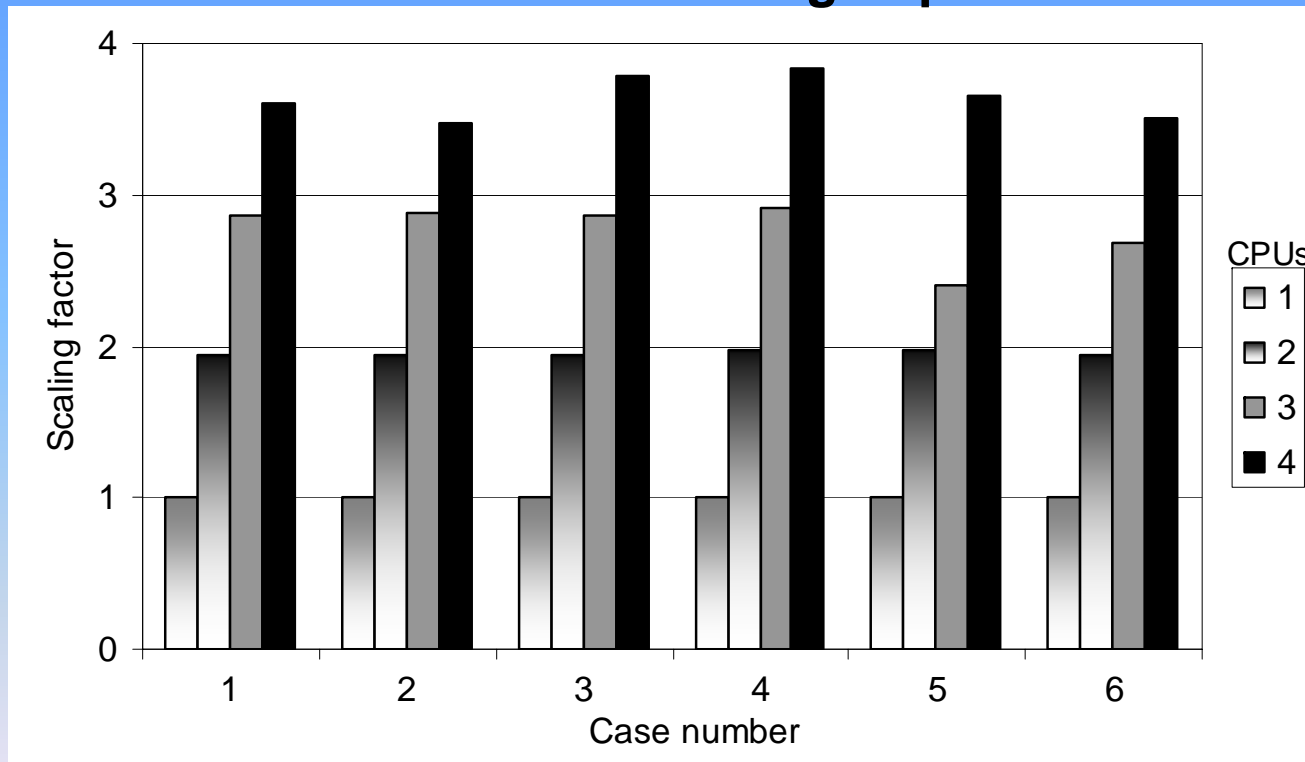

EM64T Physical processors – 4

CPU – 3192MHz Physical memory – 16GB

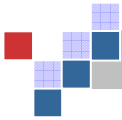

# Speedup with Multiple Threads

## Transmission line modeling

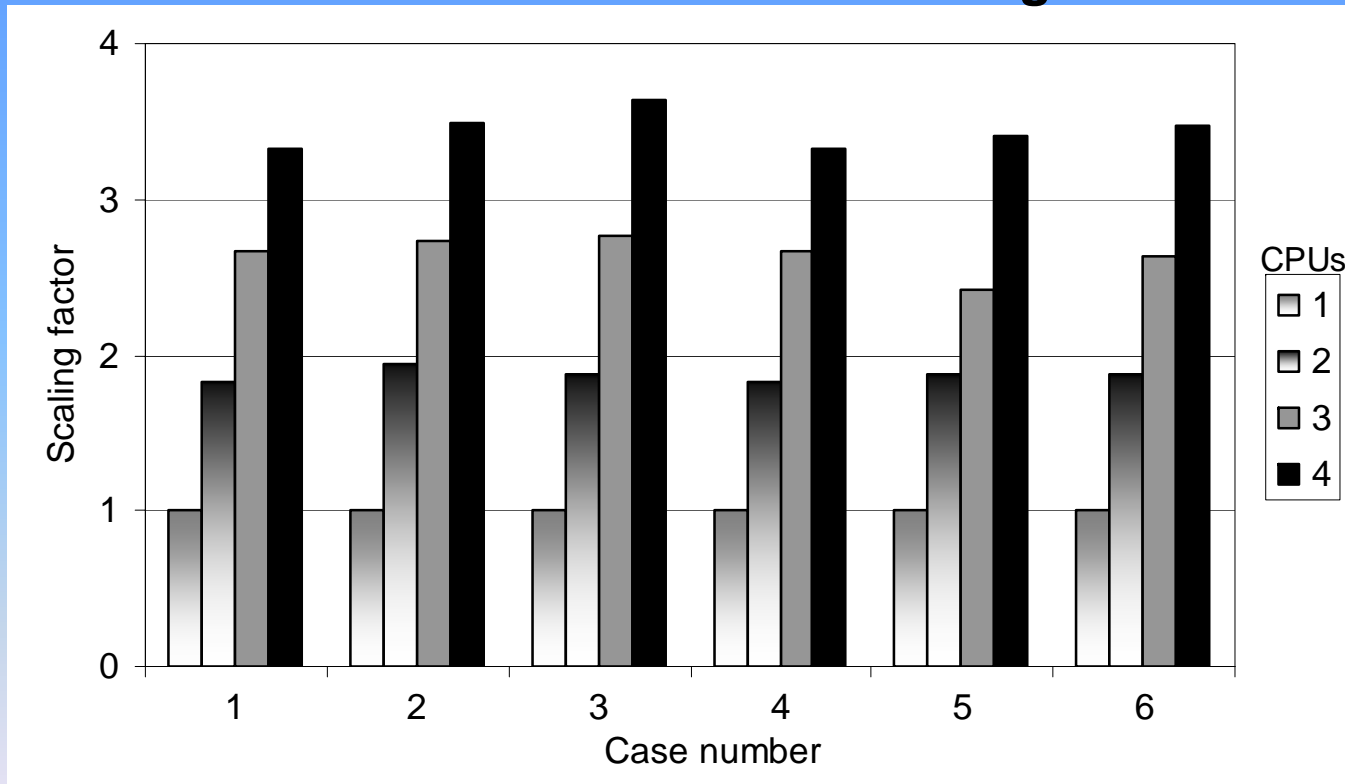

EM64T Physical processors – 4

CPU – 3192MHz Physical memory – 16GB

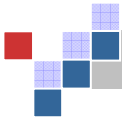

# Single Core vs. Multi-Core

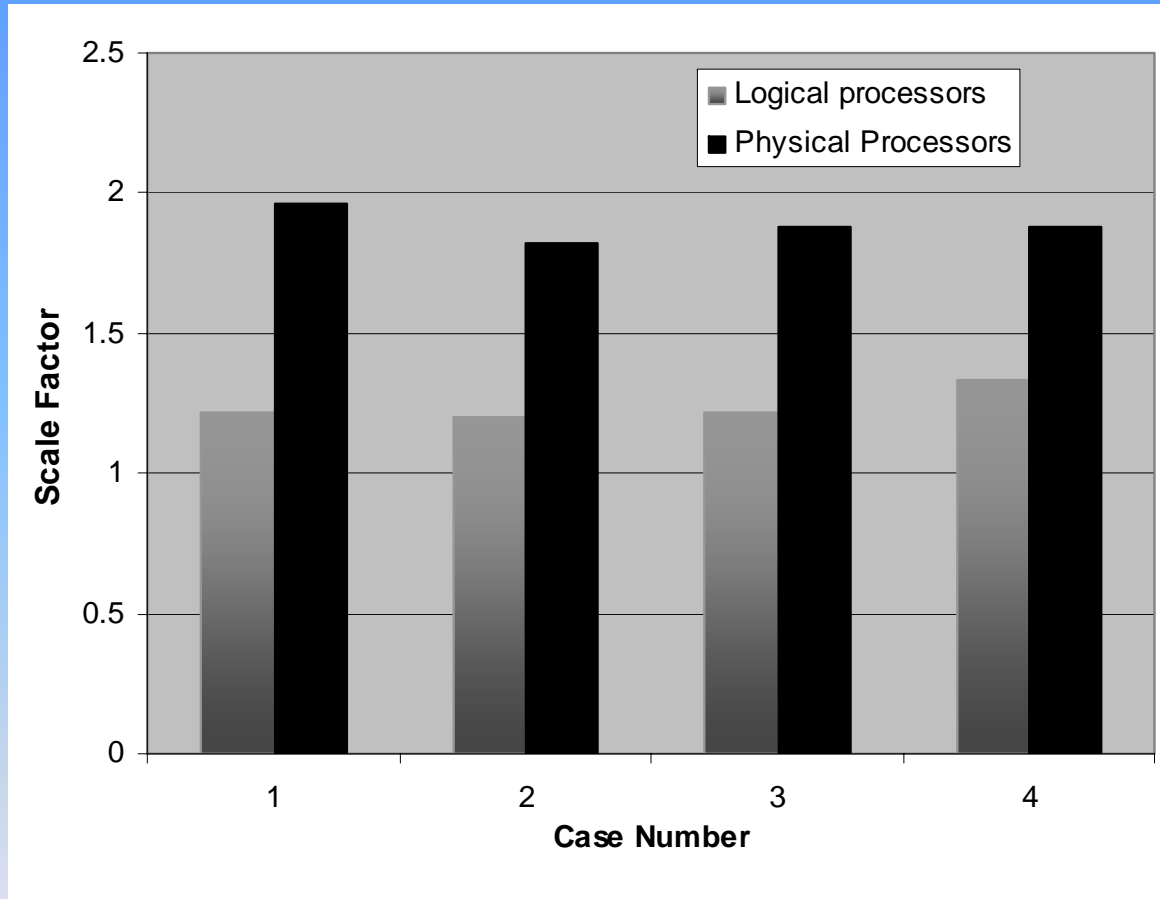

Logical processors: A single core with HT technology  
Physical processors: A dual core system

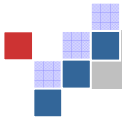

# Distributed Computing in PowerSI

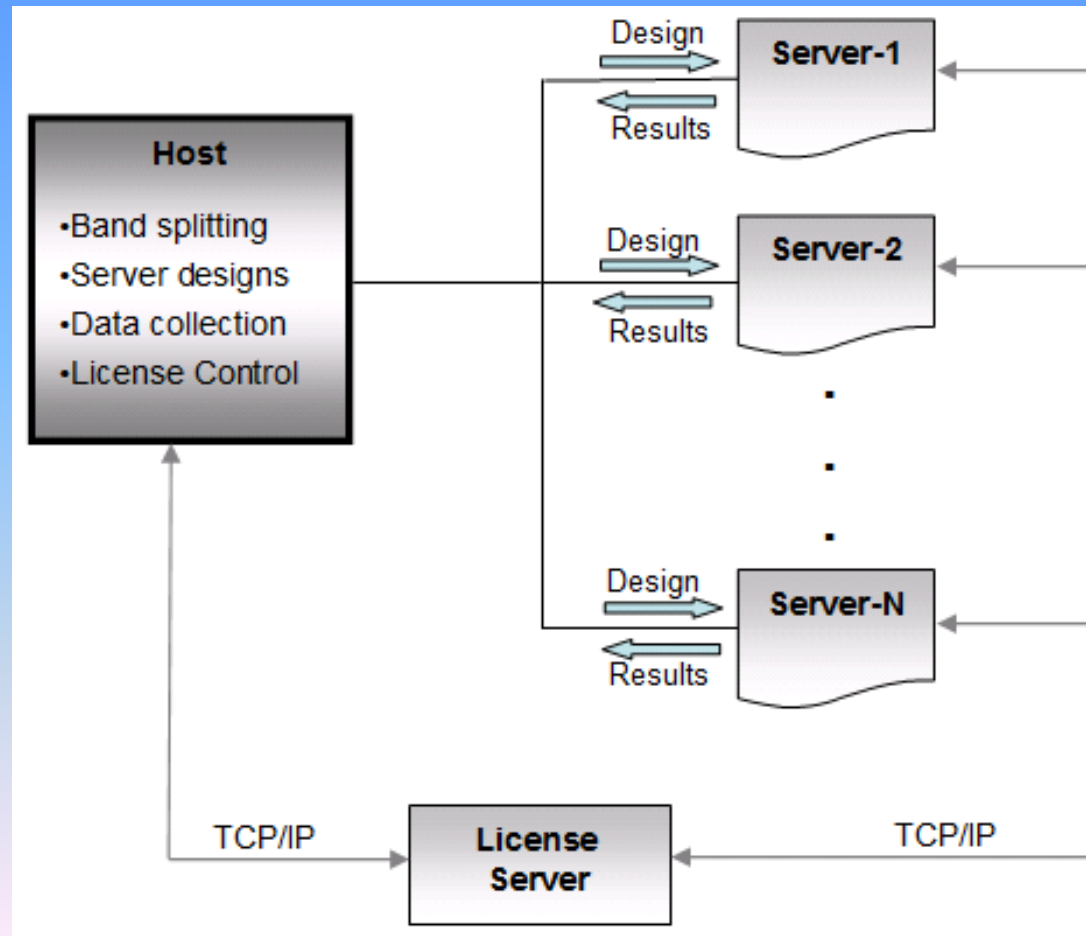



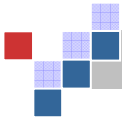

# S-parameter Extraction - PowerSI

## Description:

**Wirebond package on DDR3**

**14 layers**

**Size = 132mm x 29mm**

**# vias = 6085**

**# traces = 27,398**

**Simulation time/spot = 494s**

	Host	Host + Server	Host + two servers
Speed-Up (Time in Hours)	1 (~28)	1.88 (~14)	2.65 (~11)

Note: Host is x86 and servers are x64 machines.

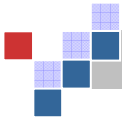

# Decap Optimization - OptimizePI

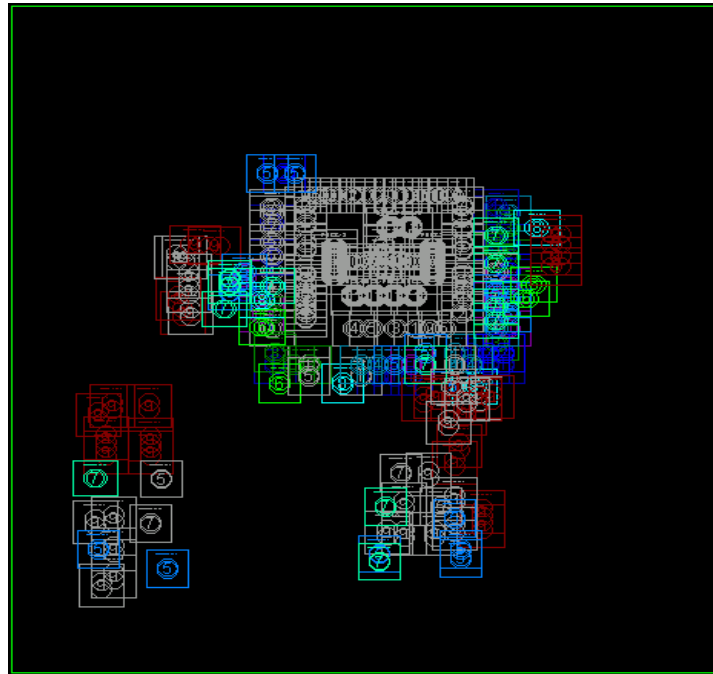

## Statistics:

30 layer FC pkg + Board

170 Decaps – Non-linear analysis

Optimized for performance/cost

10KHz – 300MHz

Potential solutions computed = 150,000

CPU1	1	2	3	4
Time	16H	8.1H	5.5H	4.2H

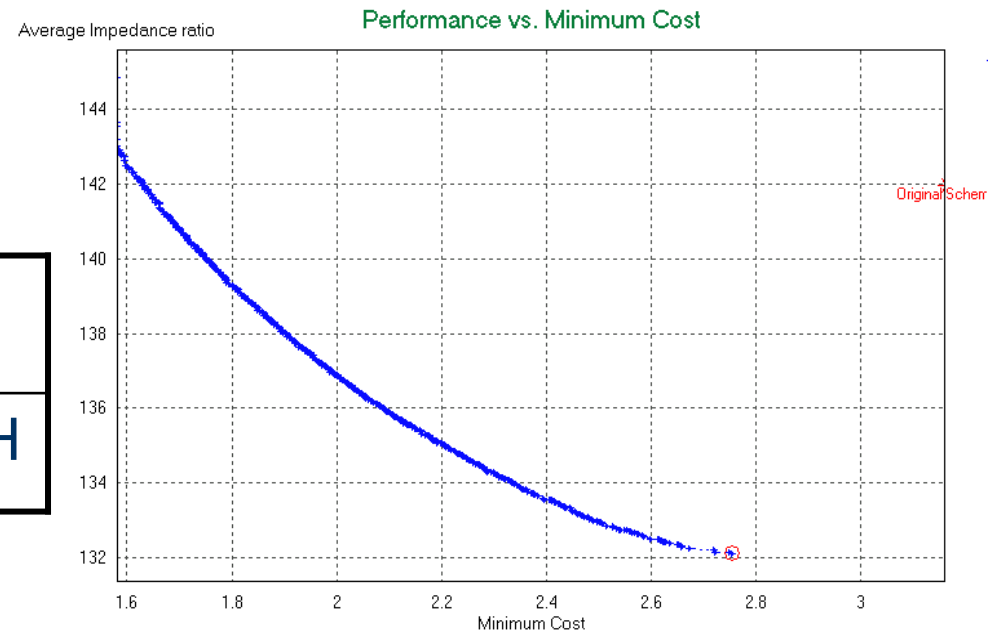

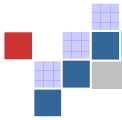

# Broadband Package Model Extraction - XtractIM

Average error in S

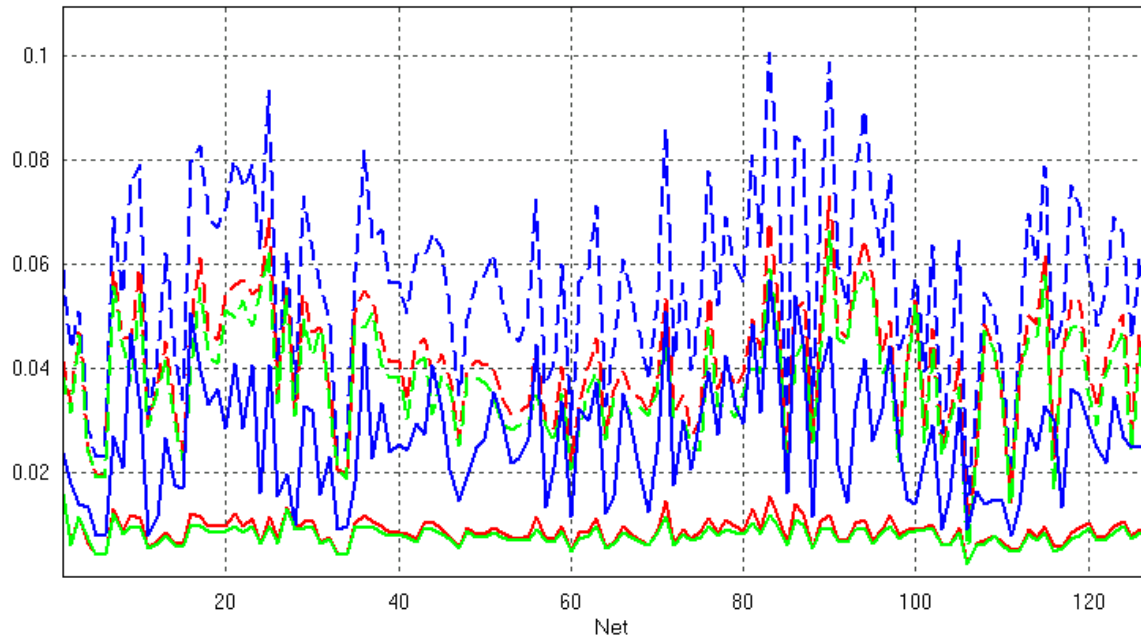

## Statistics:

8 layer FBGA package  
Full package with 128 nets  
Band: 10KHz to 5GHz  
1280 variables to optimize

CPU's	1	2	3	4
Time	8.3H	4.2H	2.85H	2.2H

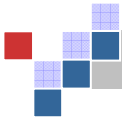

## Closing Remarks

- Concurrent threads are required to take full advantage of multi-processor/multi-core systems.
- Identify and focus on areas that will have most impact on the performance.
- Significant time savings can be realized with proper tuning, thus leading to a faster turn-around time in the layout analysis.

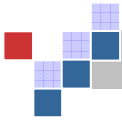

# Thank You!

Questions?

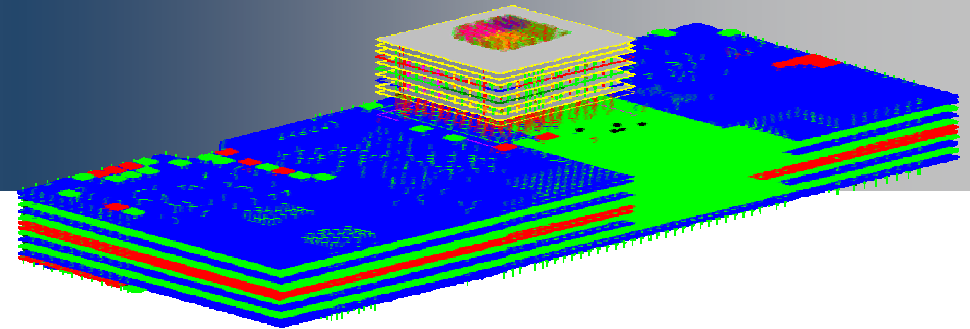

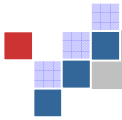

# BACKUP

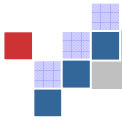

# Concepts of Multithreading

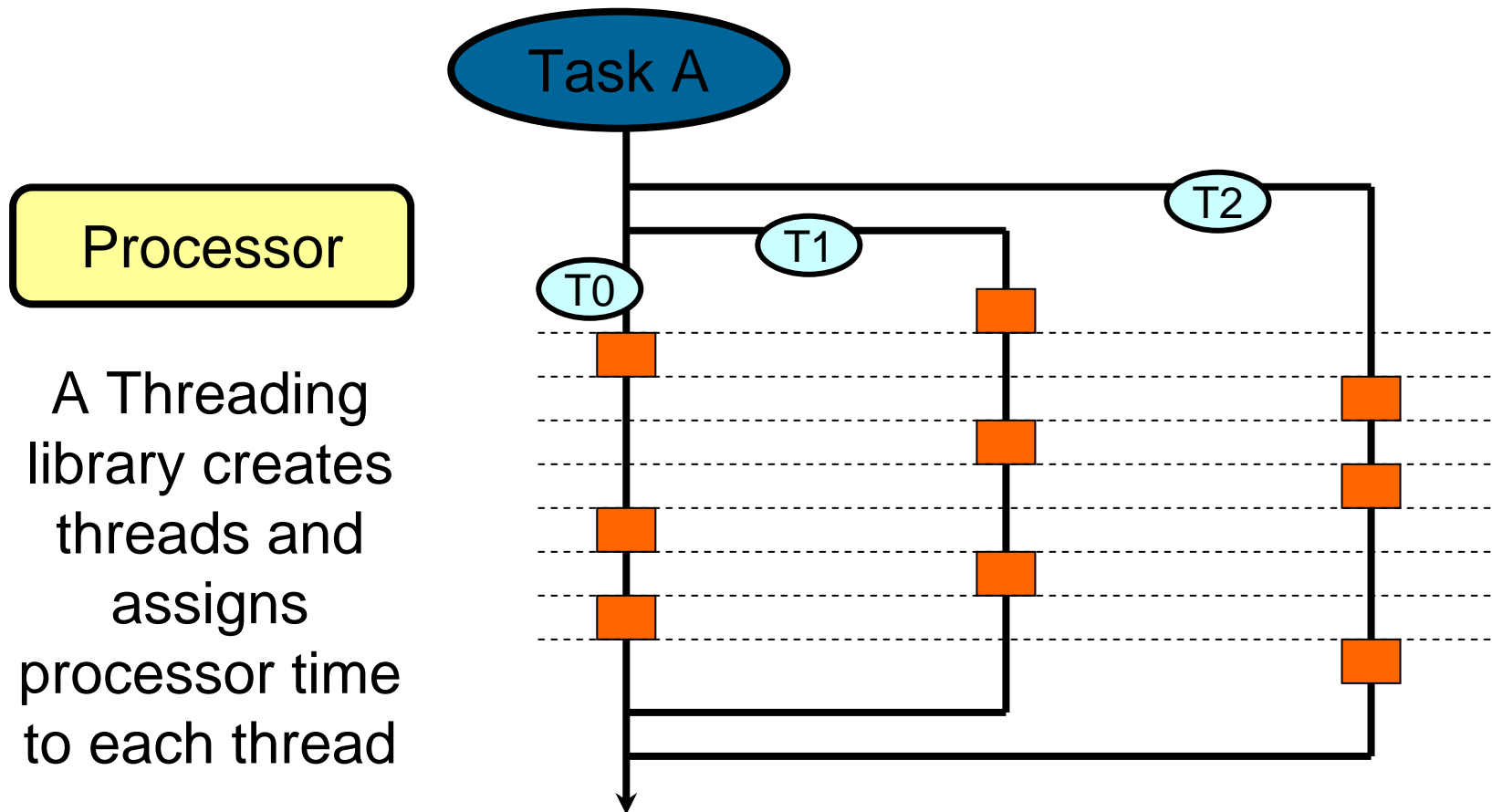

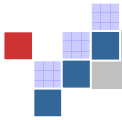

# Concepts of Multithreading

- Threads from a common Task have the same memory space (*Shared Memory*)
- They can simultaneously access variables that were instantiated before creating the threads.

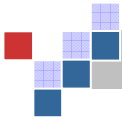

# Concepts of Multithreading

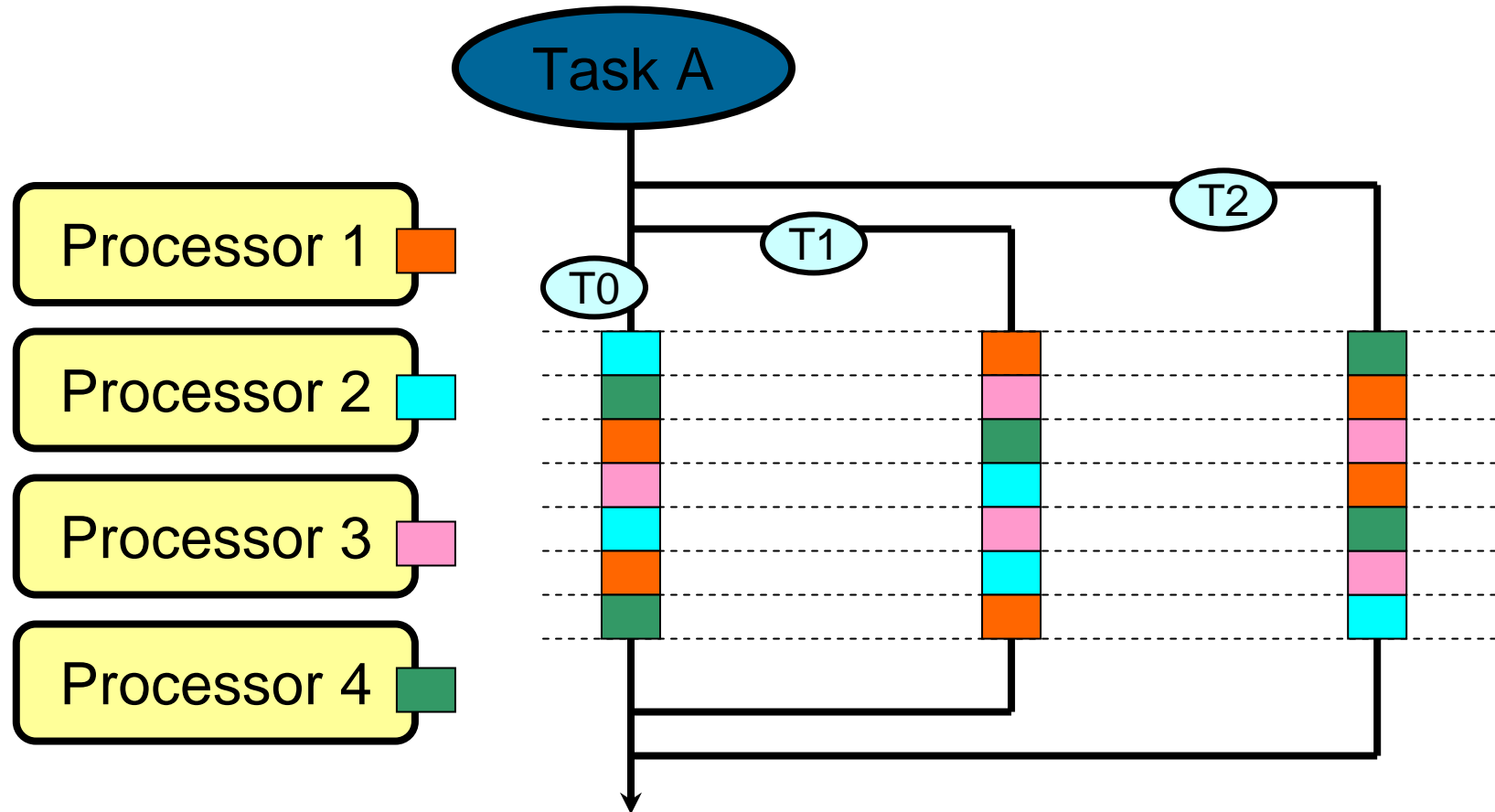

**Multiprocessor Environment**

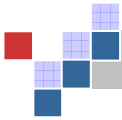

# Concepts of Multithreading

Different Threading libraries are available in different platforms

- PThreads
- SProc
- Win32 Threads